

ITS Type 2 Box

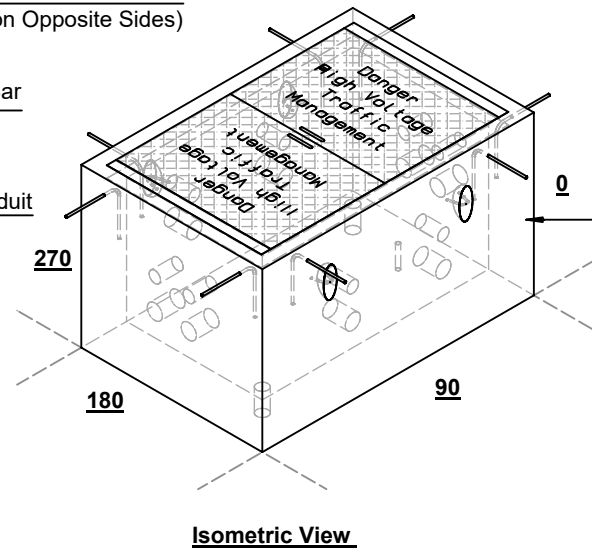
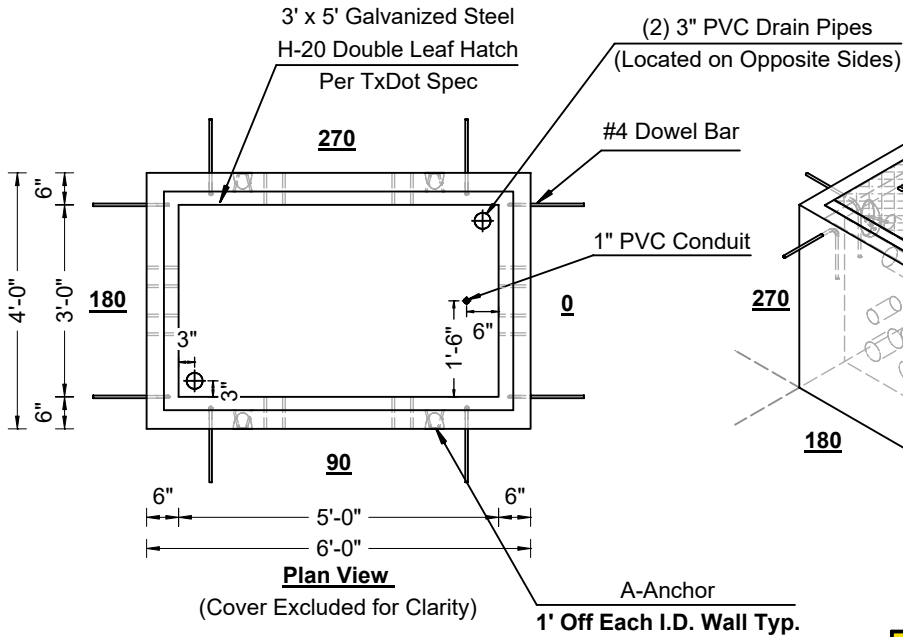

Approximate Concrete Weight

(3' Height)
WT = 5705.38 lbs

BOM	
QTY	Product
4	6CA18 Anchors
8	3" Terminators
8	4" Terminators

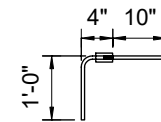

#4 Dowel Bar Detail
N.T.S

(2) 3" Terminators
(2) 4" Terminators
Per Each Wall

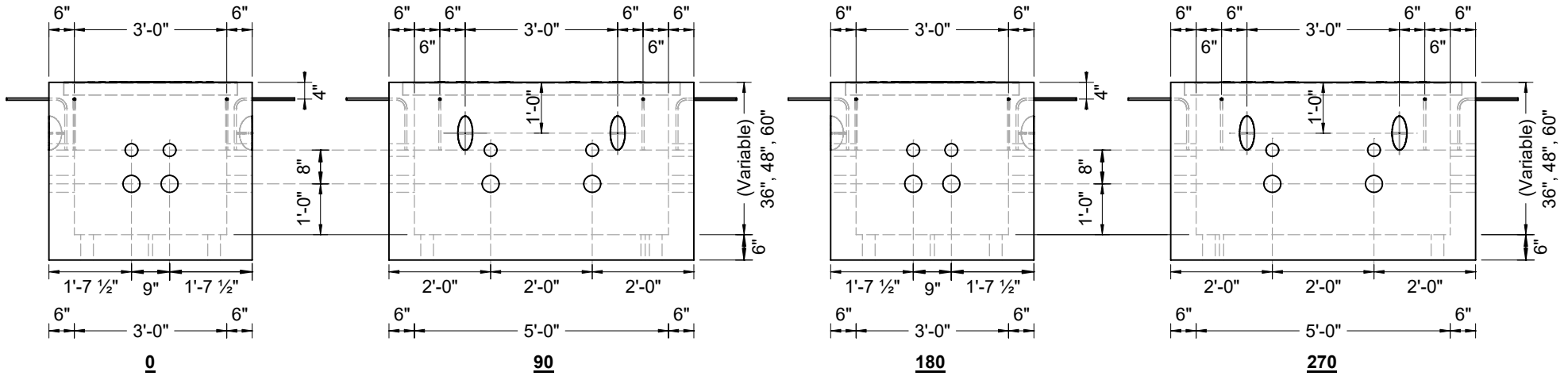

Specifications:

- Concrete has a 28 day strength of 5,000 psi
- Steel reinforcement is ASTM A615 grade 60
- Load design is H-20

6905 S. Old Bastrop Hwy
San Marcos, Tx 78666
(830) 606-6200
capitalprecastinc.com



Title: ITS Type 2 Box	
Project:	
Drawn: AC	File:
Checked:	Date: 6/5/2024 Page: 1 of 1